

# Chelsea® 680 Series

Two Gear Heavy Duty PTO  
for Mechanical Transmission



## Overview:

The Chelsea 680 PTO features a cast iron housing, cast iron bearing caps, and a press fit idler pin with tapered cone bearings and one-piece input gears to give it the highest torque rating and longest service life possible. The space saving air shift cover provides maximum clearance in tight spaces. It offers a large variety of output options including Chelsea's popular 360° rotatable and greaseable pump mount options. It has four internal speed ratios and eleven shift options to make this one versatile PTO. Take advantage of over 70 years of Chelsea PTO technology to increase performance and lower costs.

- Aerial
- Fire & Rescue
- Dump Trucks & Trailers
- Service Trucks
- Blower & Vacuum



## Contact Information:

Parker Hannifin Corporation  
**Chelsea Products Division**  
8225 Hacks Cross Road  
Olive Branch, MS 38654 USA

**Phone: 1-888-PH4-TRUK**  
**(1-888-744-8785)**

**Fax: 1-662-895-1069**  
**chelseacustserv@parker.com**

[www.parker.com/chelsea](http://www.parker.com/chelsea)

## Product Features and Benefits:

- **Coverage** – Excellent for transmissions with 8-Bolt openings
- **Housing** – Deep mount housing option for Mack applications
- **Torque** – Designed for higher torque applications such as pneumatic blowers
- **Outputs** – Twenty-eight output options
- **Shift Options** – Eleven shift options
- **Power** – Torque ratings up to 375 lbs-ft
- **Confidence** – Two Year Warranty



ENGINEERING YOUR SUCCESS.

# 680 SERIES POWER TAKE-OFF SPECIFICATIONS AND TECHNICAL DATA

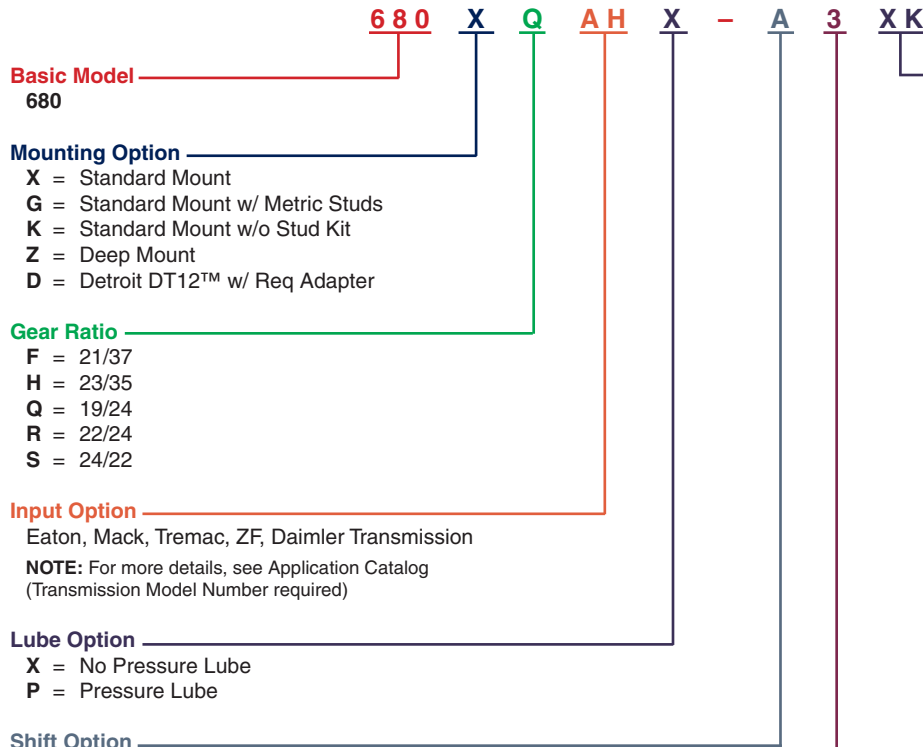

- <sup>1</sup> **A** = Air Shift
- <sup>1</sup> **P** = 12V Elec/Air Shift
- V** = Air Shift w/o Installation Kit
- <sup>21</sup> **S** = Air Shift w/ PTO/Dump Pump Combo Valve w/ Kick Out w/ Neutral Spring Return
- <sup>21</sup> **T** = Air Shift w/ PTO/Dump Pump Combo Valve w/o Kick Out w/ Neutral Spring Return
- <sup>21</sup> **U** = Air Shift w/ PTO/Dump Pump Combo Valve w/ Kick Out w/o Neutral Spring Return
- <sup>1</sup> **W** = Wire Shift
- X** = Wire Shift w/o Cable & Knob
- M** = Constant Mesh
- H** = No Shift Assembly
- C** = Special Shift Control & Bracket Kit

<sup>1</sup> Includes mounting parts.  
<sup>21</sup> Includes installation kit, console sold separately.  
<sup>59</sup> Same as XK except rotated 90°.

**Dimensions**  
**A** = 1.401" (F, S & U Ratios), 1.032" (Q & W Ratios)  
**B** = 3.007" (F, S & U Ratios), 2.908" (Q & W Ratios)  
**C** = 6.566" (Z Mount), 6.708" (X Mount), 6.345" (E Mount)  
**D** = .930" (Z Mount), 1.072" (X Mount), .709" (E Mount)

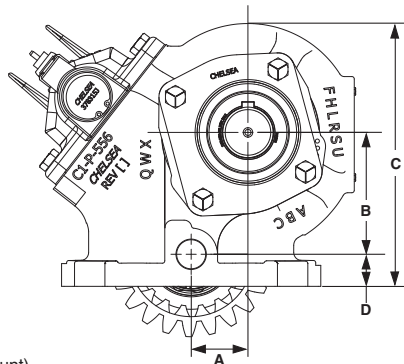

## Output Option

### Driveline Output

- XD** = Rd Standard Shaft (1-1/4" - 5/16" Key)
- XV** = 1410 Series Companion Flange
- XX** = 1-1/4" Tapered Output Shaft w/ Keyway

### Pump Mount

- AK** = SAE B 2-Bolt Flange, SAE B Shaft (7/8" - 13T)
- AZ** = SAE B 4-Bolt Flange, SAE C Shaft (1-1/4" - 14T)
- XE** = SAE A 2 or 4-Bolt Flange, SAE A Shaft (5/8" - 9T)
- <sup>59</sup> **XK** = SAE B 2 or 4-Bolt Flange, SAE B Shaft (7/8" - 13T)
- XQ** = SAE B 2 or 4-Bolt Flange, SAE B Shaft (7/8" - 13T)
- AF** = SAE B 2 or 4-Bolt Flange, SAE BB Shaft (1" - 15T)
- GA** = Greaseable SAE B 2-Bolt Rotatable Flange, SAE B Shaft (7/8" - 13T)
- GB** = Greaseable SAE B 4-Bolt Rotatable Flange, SAE B Shaft (7/8" - 13T)
- GK** = Greaseable SAE B 2 or 4-Bolt Flange, SAE B Shaft (7/8" - 13T)
- <sup>59</sup> **GQ** = Greaseable SAE B 2 or 4-Bolt Flange, SAE B Shaft (7/8" - 13T)
- GH** = Greaseable SAE B 2-Bolt Rotatable Flange, SAE BB Shaft (1" - 15T)
- GF** = Greaseable SAE B 2 or 4-Bolt Flange, SAE BB Shaft (1" - 15T)
- GZ** = Greaseable SAE B 2 or 4-Bolt Flange, SAE C Shaft (1-1/4" - 14T)
- GR** = Greaseable Chelsea Special (Cloverleaf), SAE B Shaft (7/8" - 13T)
- GY** = Greaseable ISO 7653 Pump Mount DIN 5462 Shaft
- RC** = Rotatable SAE A 2-Bolt Flange, SAE A Shaft (5/8" - 9T)
- RD** = Rotatable SAE A 2-Bolt Flange, SAE B Shaft (7/8" - 13T)
- RA** = Rotatable SAE B 2-Bolt Flange, SAE B Shaft (7/8" - 13T)
- RF** = Rotatable SAE B 2-Bolt Flange, SAE BB Shaft (1" - 15T)
- RK** = Rotatable SAE B 2 or 4-Bolt Flange, SAE B Shaft (7/8" - 13T)
- RB** = Rotatable SAE B 4-Bolt Flange, SAE B Shaft (7/8" - 13T)
- RE** = Rotatable SAE B 4-Bolt Flange, SAE BB Shaft (1" - 15T)
- RY** = Rotatable ISO 7653 Pump Mount DIN 5462 Shaft
- XR** = Chelsea Special (Cloverleaf), SAE B Shaft (7/8" - 13T)
- XY** = ISO 7653 Pump Mount DIN 5462 Shaft

## Assembly Arrangement

3, 4, 5, 6

## Specifications Chart

Approximate Weight: 28.2 lbs. [12.8 kg]

	680*F	680*H	680*Q	680*R	680*S
Intermittent Torque Rating (lbs-ft) [Nm]	375 [508]	375 [508]	375 [508]	350 [475]	325 [441]
HP Rating for Intermittent Duty					
At 500 RPM of Output Shaft (HP) [Kw]	36 [27]	36 [27]	36 [27]	33 [25]	31 [23]
At 1000 RPM of Output Shaft (HP) [Kw]	71 [53]	71 [53]	71 [53]	67 [50]	62 [46]
At 1500 RPM of Output Shaft (HP) [Kw]	107 [80]	107 [80]	107 [80]	100 [75]	93 [69]